

# KL-F11-AR Series

경·방진용, 각도조절 - Light load, Chshioning type, For angle adjustment

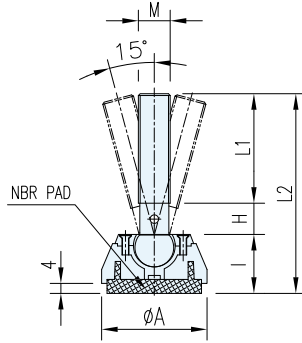

## • 제품특징 Feature

아연가공으로 부식방지, 경사진 바닥에 사용  
(Anti-corrosion with zinc processing,  
Use on sloping floors)

## • 적용범위 Application

런닝머신, 콘베어, 공작기계, 자동화설비  
(Running machine, Conveyor,  
Construction machine, Automation  
facilities)

## 규격 - Dimension & Material

Unit: mm

Model	Dimension (mm)						Road (Kg/4EA)	Material		Treatment
	M	L1	L2	H	I	ØA		Bolt & Nut	Cup	
KL-F11-AR (Zn & Steel)	M16x2.0	60	104	15	29	Ø54	1,000	S10C	Zn	Cr
		100	144							

\* 기타 특수사양은 주문제작함 (Particular case is Made-To-Order)