

# KD-C18-1/2 Series

경량형 정밀우레탄 - Light loads Precision polyurethane

KD-C18-1: Steel / KD-C18-2: STS



- 허용 하중 Allowable load  
700~900Kg/4ea
- 사용 온도 Temperature  
-10 ~ 90° C

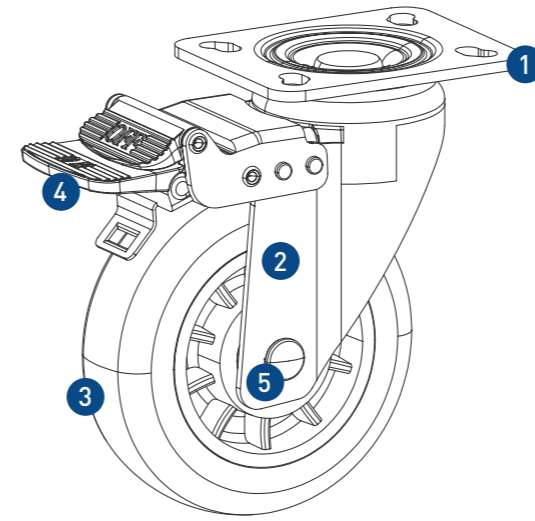

## 재질 & 표면처리 - Material & Treatment

NO.	재질	표면처리
① 상판(Top Plate)	SPC (STS)	Zinc Plating (MFZN) (-)
② 몸체(Body)	SPC (STS)	Zinc Plating (MFZN) (-)
③ 바퀴(Wheel)	Poly Urethane + PC	Green
④ 브레이크(Brake)	TPA	Light Gray
⑤ 핀(Pin)	Swrch10A/S45C (STS)	Zinc Plating (MFZN) (-)

\* Wheel Option: - Poly Urethane + AL (Blue) - NBR(WEU) + AL (Black)

## 표기법 - Ordering Code

KD-C18	1	100	SF	B
Caster Series	Function No. 1 : Steel 2 : STS	Serial Number	• SF : Swivel Flange • RF : Rigid Flange	• B : Brake

## 특징 - Features

- 무소음, 바닥손상이 없음  
No noise, no floor damage
- 듀얼 브레이크 적용  
Dual brake apply
- 구름성, 선회력 우수  
Excellent rotatory, turning performance

## 용도 - Application

- 반도체/디스플레이 제조장비  
Semiconductor/display equipment
- 식품 생산설비  
Food production equipment
- 다양한 산업용 운반구  
A various industrial transports equipment

## 규격 - Dimension

Model	자중 (Net Weight)	Kg		Ø		F		Hole	H	L	O
		1EA	4EA	Ø	W	F	F1				
KD-C18-1(2)-100SF	1.14									151	
KD-C18-1(2)-100SFB	1.3	240	700	Ø100	40	105x85	80x60 74x45	Ø9x14 (slot hole)	139	178.5	48
KD-C18-1(2)-100RF	0.8									105	-
KD-C18-1(2)-125SF	1.27									158	
KD-C18-1(2)-125SFB	1.44	270	800	Ø125	40	105x85	80x60 74x45	Ø9x14 (slot hole)	167.5	178.5	42.5
KD-C18-1(2)-125RF	0.95									125	-
KD-C18-1(2)-150SF	1.6									164.5	
KD-C18-1(2)-150SFB	1.43	300	900	Ø150	40	105x85	80x60 74x45	Ø9x14 (slot hole)	191	178.5	36.5
KD-C18-1(2)-150RF	1.1									150	-

Unit: mm