

# KD-C10-1 Series

고하중 캐스터 - High-loads caster

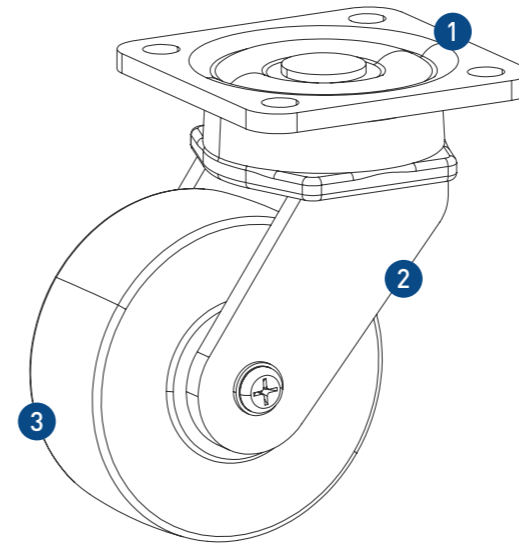

- 허용 하중 Allowable load  
1,200~2,400Kg/4ea
- 사용 온도 Temperature  
-10 ~ 90° C



## 재질 & 표면처리 - Material & Treatment

NO.	재질	표면처리
① 상판(Top Plate)	SPC	Black Coated
② 몸체(Body)	S45C	Black Coated
③ 바퀴(Wheel)	MC Nylon	Ivory or Blue
	Poly Urethane+AL	-

## 표기법 - Ordering Code

<b>KD-C10</b>	<b>1</b>	<b>75</b>	<b>SF</b>	<b>M</b>
Caster Series	Function No.	Serial Number	<ul style="list-style-type: none"> <li>• SF : Swivel Flange</li> <li>• RF : Rigid Flange</li> </ul>	<ul style="list-style-type: none"> <li>• M : MC Nylon</li> <li>• U : P/Urethane</li> </ul>

## 특징 - Features

- 구름성, 선회력 우수  
Excellent rotatory, turning performance
- 저소음, 저마찰성  
Low noise, low friction
- 고하중용 캐스터  
High-load caster

## 용도 - Application

- 반도체 제조장비  
Semiconductor equipment
- 이화학기기, 실험장비  
Chemical instrument, tests equipment
- 각종 운반대차  
A variety of cartwheels

## 규격 - Dimension

Unit: mm

Model	자중 (Net Weight) Kg	Kg		W		HOLE			H								
		1EA	4EA	Ø	W	F	F1	Hole	H	L	O						
KD-C10-1-75RF-M	1.2	650	1,950	Ø75	48	95x95	70x70	Ø11	113	95	-						
KD-C10-1-75SF-M	1.7				48					119	34						
KD-C10-1-75RF-U	1.3	40	95		-												
KD-C10-1-75SF-U	1.8		119		34												
KD-C10-1-100RF-M	1.4	700	2,100	Ø100	48				95x95	70x70	Ø11	138	100	-			
KD-C10-1-100SF-M	1.9				48								137	39.5			
KD-C10-1-100RF-U	1.6	40	100		-												
KD-C10-1-100SF-U	2.2		137		39.5												
KD-C10-1-125RF-M	1.6	750	2,250	Ø125	48							95x95	70x70	Ø11	162.5	125	-
KD-C10-1-125SF-M	2.2				48											154.5	44.5
KD-C10-1-125RF-U	1.7	500	1,500		40											125	-
KD-C10-1-125SF-U	2.3															154.5	44.5
KD-C10-1-150RF-M	1.9	800	2,400	Ø150	48	95x95	70x70	Ø11							185	150	-
KD-C10-1-150SF-M	2.4				48											170.5	48
KD-C10-1-150RF-U	2	550	1,650		40											150	-
KD-C10-1-150SF-U	2.5															170.5	48