

KD-C08-1 Series

중하중 캐스터 - Medium-load Caster

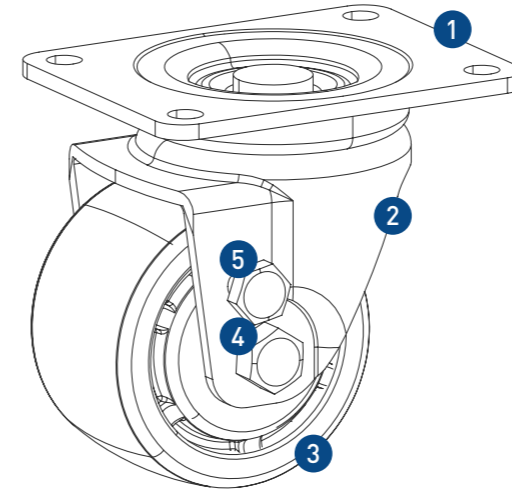

- 허용 하중 Allowable load
750~900Kg/4ea
- 사용 온도 Temperature
-10 ~ 90° C



재질 & 표면처리 - Material & Treatment

NO.	재질	표면처리
① 상판(Top Plate)	SPC	Zinc Plating (MFZN)
② 몸체(Body)	SPC	Zinc Plating (MFZN)
③ 바퀴(Wheel)	HDP	Black
④ 볼트(Bolt)	Swrch10A/S45C	Zinc Plating (MFZN)
⑤ 브레이크(Brake)	Swrch10A/S45C	Zinc Plating (MFZN)

표기법 - Ordering Code

KD-C08	1	8030	F
Caster Series	Function No.	Serial Number	• F : Flange

규격 - Dimension

Unit: mm

Model	자중 (Net Weight) Kg	Kg		Ø		HOLE			H	L	O
		1EA	4EA	Ø	W	F	F1	Hole			
KD-C08-1-8030F	1.05	250	750	Ø76	47	105x80	85.5x60.5	Ø9	103	111.5	21
KD-C08-1-8040F	1.25	300	900	Ø102	47	105x80	85.5x60.5	Ø9	130	130.5	27

특징 - Features

- 저상형 캐스터
Low height caster
- 이중 베어링 사용
Use double bearings
- 회전력 극대화
Maximize rotational force

용도 - Application

- 병원용 고급장비
Advanced equipment for hospitals
- 컴퓨터 주변기기 및 전산기기
Computer Peripherals and devices equipment
- 첨단 기계장비 및 운반장비
Mechanical and Transportation equipment