

# KD-C07-1 Series

회전반경 최적화 - Optimizing the radius of rotation

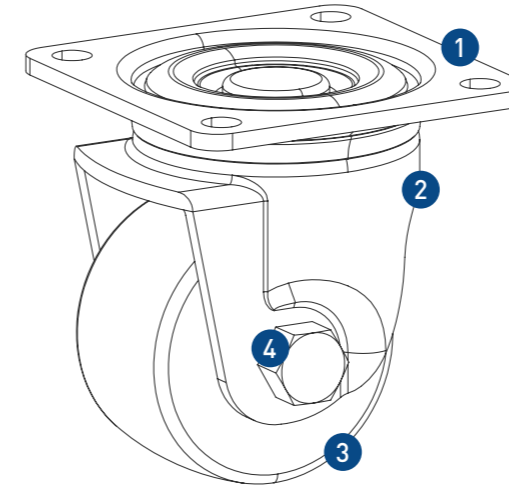

- 허용 하중 Allowable load  
1,800~3,240Kg/4ea
- 사용 온도 Temperature  
-10 ~ 90° C



## 재질 & 표면처리 - Material & Treatment

NO.	재질	표면처리
① 상판(Top Plate)	SPC	Zinc Plating (MFZN)
② 몸체(Body)	SPC	Zinc Plating (MFZN)
③ 바퀴(Wheel)	M/C Nylon	Black
④ 볼트(Bolt)	Swrch10A/S45C	Zinc Plating (MFZN)

## 표기법 - Ordering Code

<b>KD-C07</b>	<b>1</b>	<b>75</b>	<b>SF</b>
Caster Series	Function No.	Serial Number	• SF : Swivel Flange

## 특징 - Features

- 저상형 캐스터  
Low height caster
- 이중 베어링 사용  
Use double bearings
- 회전반경 최적화  
Optimizing the radius of rotation

## 용도 - Application

- 병원용 고급장비  
Advanced equipment for hospitals
- 컴퓨터 주변기기 및 전산기기  
Computer Peripherals and devices equipment
- 첨단 기계장비 및 운반장비  
Mechanical and Transportation equipment

## 규격 - Dimension

Unit: mm

Model	자중 (Net Weight) Kg	Kg		W		HOLE			H	L	O
		1EA	4EA	Ø	W	F	F1	Hole			
KD-C07-1-50SF	1.16	600	1,800	Ø50	38	84x84	64x64	Ø8.5	79	84	12
KD-C07-1-65SF	1.42	600	1,800	Ø65	48	100x100	78x78	Ø10.5	97	100	14
KD-C07-1-75SF	1.62	720	2,160	Ø75	48	100x100	78x78	Ø10.5	107	101.5	14
KD-C07-1-100SF	2.38	1,080	3,240	Ø100	48	150x110	121x59	Ø13	140	150	20