

# KD-C06-1 Series

저상형 캐스터 - Low height caster



- 허용 하중 Allowable load  
1,500~1,800Kg/4ea
- 사용 온도 Temperature  
-10 ~ 90° C

## 표기법 - Ordering Code

<b>KD-C06</b>	<b>1</b>	<b>60</b>	<b>SF</b>
Caster Series	Function No.	Serial Number	<ul style="list-style-type: none"> <li>• SF : Swivel Flange</li> <li>• RF : Rigid Flange</li> <li>• SS : Swivel Stem</li> </ul>

## 특징 - Features

- 저상형 캐스터, 볼베어링 사용  
Low height caster, Use ball bearings
- 무소음, 무유격  
Noiselessness, No assembly gap
- 회전력 극대화  
Maximize rotational force

## 용도 - Application

- 고하중 장비  
High-load equipment
- 각종 고하중 운반구  
A variety of high-load transporters

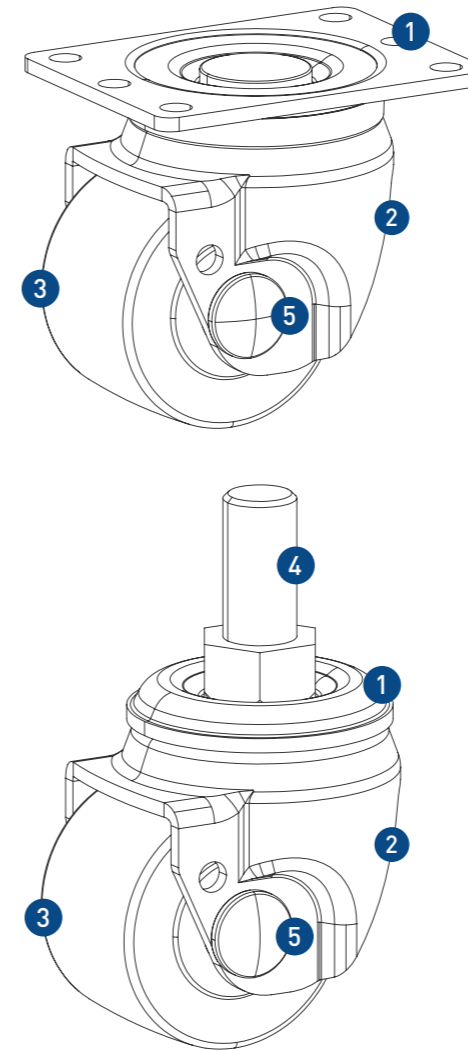

## 재질 & 표면처리 - Material & Treatment

NO.	재질	표면처리
① 상판(Top Plate)	SPC	Zinc Plating (MFZN)
② 몸체(Body)	SPC	Zinc Plating (MFZN)
③ 바퀴(Wheel)	POK	Black
④ 볼트(Bolt)	S45C	Zinc Plating (MFZN)
⑤ 핀(Pin)	Swrch10A/S45C	Zinc Plating (MFZN)

## 규격 - Dimension

Unit: mm

Model	자중 (Net Weight)	Kg		W		HOLE				H			M		Y
		1EA	4EA	∅	W	F	F1	F2	Hole	H	L	O	M	Y	
KD-C06-1-60RF	0.66	500	1,500	∅60	48	105x80	86x61	90	∅9	87	105	-	-	-	
KD-C06-1-60SF	1.1	500	1,500			-	-	-	98	89	21	M20	40		
KD-C06-1-60SS	1.2	500	1,500			-	-	-	98	89	21	M20	40		
KD-C06-1-70RF	0.7	600	1,800	∅70	48	105x80	86x61	90	∅9	97	105	-	-	-	
KD-C06-1-70SF	1.2	600	1,800			-	-	-	97	108.5	21	-	-		
KD-C06-1-70SS	1.3	600	1,800			-	-	-	108	94	21	M20	40		