

KD-C04-3 Series

저상형 캐스터 - Low height caster

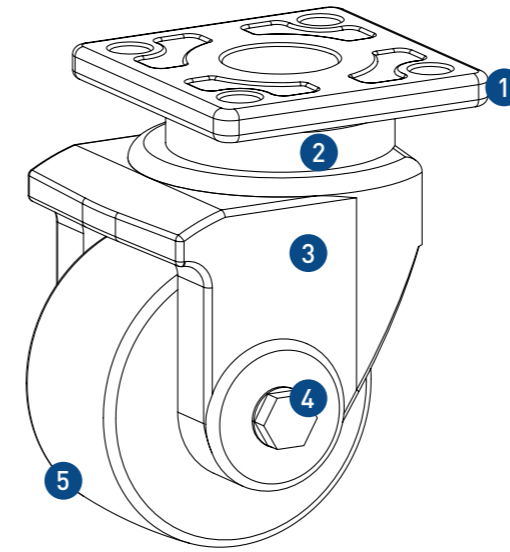

- 허용 하중 Allowable load
3,000Kg/4ea
- 사용 온도 Temperature
-10 ~ 90° C



재질 & 표면처리 - Material & Treatment

NO.	재질	표면처리
① 상판(Top Plate)	S45C	Powder Coated
② 강구(Ball)	STB2	-
③ 몸체(Body)	ALDC12	Ivory/Powder Coated
④ 핀(Pin)	Swrch10A/S45C	Zinc Plating (MFZN)
⑤ 바퀴(Wheel)	MC Nylon	Ivory or Blue
	Poly Urethane+AL	-

* Wheel Option: Poly urethane & MC Nylon by order

표기법 - Ordering Code

KD-C04	3	100	F	M
Caster Series	Function No.	Serial Number	• F : Flange	• M : MC Nylon • U : P/Urethane

규격 - Dimension

Unit: mm

Model	자중 (Net Weight) Kg	Kg		W		HOLE			H	L	O
		1EA	4EA	∅	W	F	F1	Hole			
KD-C04-3-100F-M	2.75	1,000	3,000	∅100	50	100x100	70x70	∅13	150	130	30
KD-C04-3-100F-U	3.02	1,000	3,000	∅100	50	100x100	70x70	∅13	150	130	30

특징 - Features

- 높이 제한이 있는 장비
height-limited equipment
- 베어링사용, 회전성/구름성 우수
Use of bearings, excellent rotatory performance
- 고하중용 캐스터
High-load caster

용도 - Application

- 반도체/디스플레이 제조장비
Semiconductor/display equipment
- 통신/실험/의료장비
Communications/tests/medical equipment
- 프로파일 프레임장비 등
Profile Frame Equipment/etc.