

KD-C04-2 Series

저상형 캐스터 - Low height caster

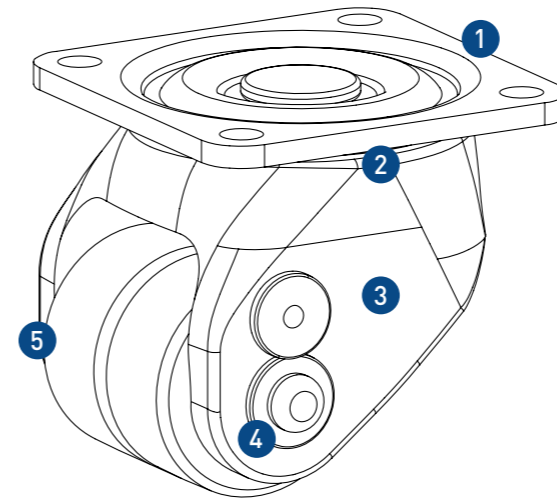

- 허용 하중 Allowable load
1,700~2,100Kg/4ea
- 사용 온도 Temperature
-10 ~ 90° C



재질 & 표면처리 - Material & Treatment

NO.	재질	표면처리
① 상판(Top Plate)	SPC/S45C	Powder Coated
② 강구(Ball)	STB2	-
③ 몸체(Body)	ALDC12	Ivory/Powder Coated
④ 핀(Pin)	Swrch10A/S45C	Zinc Plating (MFZN)
⑤ 바퀴(Wheel)	PA6	Black

* Wheel Option: Poly urethane & MC Nylon by order

표기법 - Ordering Code

KD-C04	2	60	F
Caster Series	Function No.	Serial Number	<ul style="list-style-type: none"> • F : Flange • S : Stem

특징 - Features

- 높이 제한이 있는 장비
height-limited equipment
- 트윈휠 사용으로 선회력 우수
Excellent turning performance by using twin wheels
- 360도 회전기능 일체화
Integrated 360° rotation capability

용도 - Application

- 반도체/디스플레이 제조장비
Semiconductor/display equipment
- 통신/실험/의료장비
Communications/tests/medical equipment
- 프로파일 프레임장비 등
Profile Frame Equipment/etc.

규격 - Dimension

Unit: mm

Model	자중 (Net Weight)	Kg		Ø	W	F	F1	Hole	Tap	X	Y	H	L	O
		1EA	4EA											
KD-C04-2-60F	0.78	550	1,700	Ø50	25x2	90x90	70x70	Ø9	-	-	-	85	95	25
KD-C04-2-60S	0.89	550	1,700	Ø50		-	-	-	M12 (M16)	69	65		88.5	25
KD-C04-2-75F	1.06	700	2,100	Ø73	26x2	90x90	70x70	Ø9	-	-	-	106	106.5	25
KD-C04-2-75S	1.24	700	2,100	Ø73		-	-	-	M12 (M16)	69	65		100	25