

KD-C03-2 Series

높낮이조절 캐스터 - High and low adjustment caster



- 허용 하중 Allowable load
400~800Kg/4ea
- 사용 온도 Temperature
-10 ~ 90° C

표기법 - Ordering Code

| | | | |
|---------------|--------------|---------------|------------|
| KD-C03 | 2 | 400 | S |
| Caster Series | Function No. | Serial Number | • S : Stem |

특징 - Features

- 높낮이 조절, 방진기능
Adjustable height, anti-vibration
- 저상형 캐스터
Low height caster
- 선회력 우수
Excellent turning performance

용도 - Application

- 반도체 제조설비
Semiconductor manufacturing facilities
- ATM장비 및 통신장비
ATM and Communication equipment
- 시험설비
Small test equipment

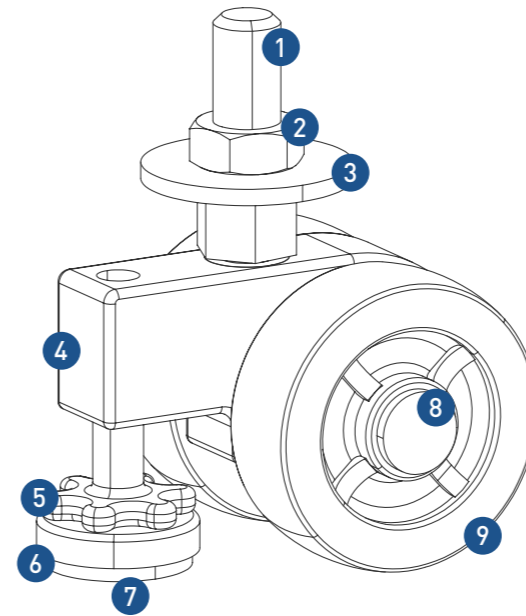

재질 & 표면처리 - Material & Treatment

| NO. | 재질 | 표면처리 |
|--------------------|----------------|---------------------|
| ①② 볼트/너트(Bolt/Nut) | Swrch10A | Zinc Plating (MFZN) |
| ③ 와셔(Washer) | SPC | Zinc Plating (MFZN) |
| ④ 몸체(Body) | ALDC12 | Black |
| ⑤ 레벨러(Leveler) | Swrch10A | Zinc Plating (MFZN) |
| ⑥ 훑컵(Foot cup) | SPC | Zinc Plating (MFZN) |
| ⑦ 훑패드(Foot pad) | NBR & Urethane | Black |
| ⑧ 핀(Pin) | Swrch10A | Zinc Plating (MFZN) |
| ⑨ 바퀴(Wheel) | PA6 | Black |

규격 - Dimension

Unit: mm

| Model | 자중 (Net Weight) | Kg | | W | | H | L | | | M | | Y |
|---------------|--------------------|-----|-----|-----|------|----|----|-----|----|-----|----|---|
| | | 1EA | 4EA | Ø | W | | I | L | O | M | | |
| KD-C03-2-400S | 0.44 | 140 | 400 | Ø50 | 25x2 | 76 | 10 | 95 | 20 | M12 | 36 | |
| KD-C03-2-800S | 0.72 | 270 | 800 | Ø72 | 25x2 | 96 | 13 | 111 | 22 | M16 | 36 | |