

KD-C03-1 Series

높낮이조절 캐스터 - High and low adjustment caster



- 허용 하중 Allowable load
400~800Kg/4ea
- 사용 온도 Temperature
-10 ~ 90° C

표기법 - Ordering Code

KD-C03	1	400	F
Caster Series	Function No.	Serial Number	• F : Flange

특징 - Features

- 높낮이 조절, 방진기능
Adjustable height, anti-vibration
- 저상형 캐스터
Low height caster
- 선회력 우수
Excellent turning performance

용도 - Application

- 반도체 제조설비
Semiconductor manufacturing facilities
- ATM장비 및 통신장비
ATM and Communication equipment
- 시험설비
Small test equipment

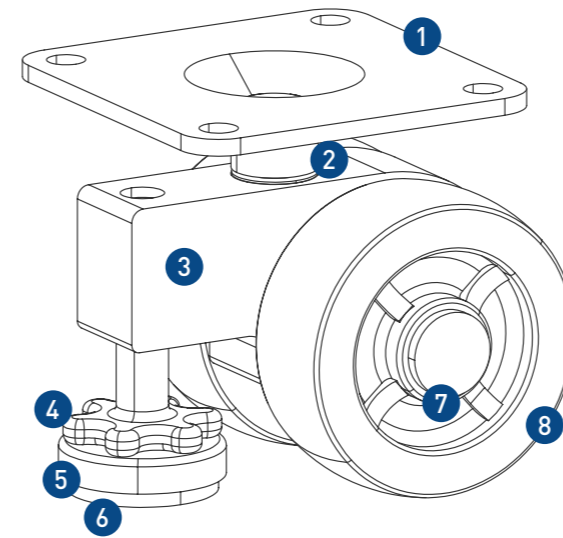

재질 & 표면처리 - Material & Treatment

NO.	재질	표면처리
① 상판(Top Plate)	SPC	Zinc Plating (MFZN)
② 샤프트(Shaft)	Swrch10A	Zinc Plating (MFZN)
③ 몸체(Body)	ALDC12	Black
④ 레벨러(Leveler)	Swrch10A	Zinc Plating (MFZN)
⑤ 훑컵(Foot cup)	SPC	Zinc Plating (MFZN)
⑥ 훑패드(Foot pad)	NBR & Urethane	Black
⑦ 핀(Pin)	Swrch10A	Zinc Plating (MFZN)
⑧ 바퀴(Wheel)	PA6	Black

규격 - Dimension

Unit: mm

Model	자중 (Net Weight)	Kg		W		HOLE			L			
		Kg	1EA	4EA	∅	W	F	F1	Hole	H	I	L
KD-C03-1-400F	0.62	140	400	∅50	25x2	90x90	70x70	∅9	76	10	95	20
KD-C03-1-800F	0.88	270	800	∅72	25x2	90x90	70x70	∅9	96	13	111	22