

KD-C02-2 Series

높낮이조절 캐스터 - High and low adjustment caster

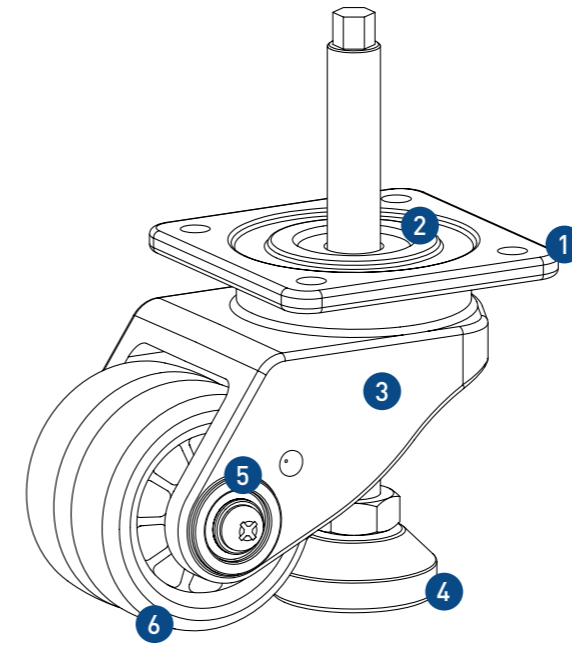

- 허용 하중 Allowable load
2,400Kg/4ea
- 사용 온도 Temperature
-10 ~ 90° C



재질 & 표면처리 - Material & Treatment

NO.	재질	표면처리
① 상판(Top Plate)	SPC/S45C	Powder Coated
② 강구(Ball)	STB2	-
③ 몸체(Body)	ALDC12	Ivory/Powder Coated
④ 컵(Cup)	SPC/ALDC12	Ni
⑤ 핀(Pin)	Swrch10A/S45C	Zinc Plating (MFZN)
⑥ 바퀴(Wheel)	PA6	Black

* Wheel Option: Poly urethane & MC Nylon by order

표기법 - Ordering Code

KD-C02	2	1000	F
Caster Series	Function No.	Serial Number	• F : Flange

규격 - Dimension

Unit: mm

Model	자중 (Net Weight)	Kg		Ø	W	HOLE			H+	L	O	Ø1	M	S
		1EA	4EA			F	F1	Hole						
KD-C02-2-1000F	1.85	800	2,400	Ø73	26x2	90x90	70x70	Ø9	108+60	151.5	70	50	16	11

특징 - Features

- 큰폭의 높낮이 조절
Large height Adjustable
- 손쉬운 이동, 고정성
Easy moving, fixing
- 트윈휠 사용으로 선회력 우수
Excellent turning performance by using twin wheels

용도 - Application

- 반도체/디스플레이 제조장비
Semiconductor/display equipment
- 자동화장비/컨베이어
Automation equipment/conveyors
- 프로파일 프레임장비 등
Profile Frame Equipment/etc.