

# KD-C01-3 Series

높낮이조절 캐스터 - High and low adjustment caster



- 허용 하중 Allowable load  
500~1,000Kg/4ea
- 사용 온도 Temperature  
-10 ~ 90° C

## 표기법 - Ordering Code

<b>KD-C01</b>	<b>3</b>	<b>100</b>	<b>F</b>	<b>M</b>
Caster Series	Function No.	Serial Number	<ul style="list-style-type: none"> <li>• F : Flange</li> <li>• S : Stem</li> </ul>	<ul style="list-style-type: none"> <li>• Blank : Nylon</li> <li>• M : MC Nylon</li> <li>• U : Polyurethane</li> </ul>

## 특징 - Features

- 높낮이 조절, 방진 기능  
Adjustable height, anti-vibration
- 손쉬운 이동, 고정성  
Easy moving, fixing
- 360도 회전기능 일체화  
Integrated 360° rotation capability

## 용도 - Application

- 수분/염분 등 부식방지용 장비  
Moisture/salt, anti-corrosive equipment
- 식품 및 주류장비  
Food and Liquor Equipment
- 이화학기기  
Chemical equipment

## 재질 & 표면처리 - Material & Treatment

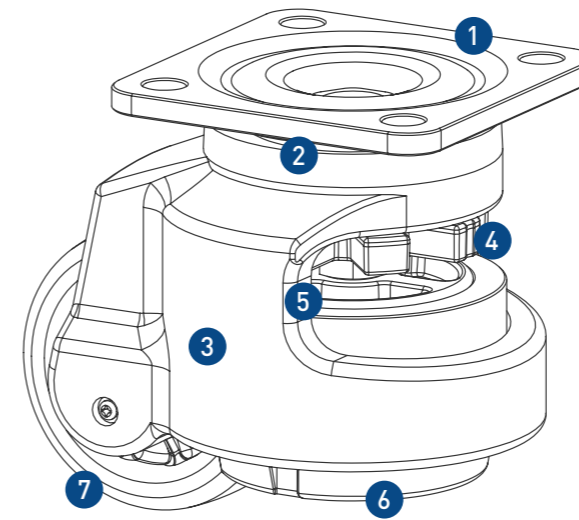

NO.	재질	표면처리
① 상판(Top Plate)	STS	-
② 강구(Ball)	STS	-
③ 몸체(Body)	STS	-
④ 핸들(Handle)	PA6	Red
⑤ 레벨러(Leveler)	STS	-
⑥ 패드(Pad)	NBR	Black
⑦ 바퀴(Wheel)	PA6	Black

\* Wheel Option: Poly urethane & MC Nylon by order

## 규격 - Dimension

Unit: mm

Model	자중 (Net Weight)	Kg		Ø	W	F	F1	Hole	Tap	X	Y	H+	L	O
		1EA	4EA											
KD-C01-3-60F	1.2	250	500	Ø50	25	73x73	58x58	Ø7	-	-	-	82+10	97.5	36
KD-C01-3-60S	1.02					-	-	-	M12 (M16)	52	45			
KD-C01-3-80F	2.02	500	1,000	Ø62	28	90x90	70x70	Ø9	-	-	-	103+15	121	45
KD-C01-3-80S	1.8					-	-	-	M12 (M16)	69	65			