

KD-C01-1 Series

높낮이조절 캐스터 - High and low adjustment caster



- 허용 하중 Allowable load
100~3,000kg (4ea)
- 사용 온도 Temperature
-10 ~ 90° C

표기법 - Ordering Code

KD-C01	1	100	F	M
Caster Series	Function No.	Serial Number	<ul style="list-style-type: none"> • F : Flange • S : Stem 	<ul style="list-style-type: none"> • Blank : Nylon • M : MC Nylon • U : Polyurethane

특징 - Features

- 높낮이 조절, 방진 기능
Adjustable height, anti-vibration
- 손쉬운 이동, 고정성
Easy moving, fixing
- 360도 회전기능 일체화
Integrated 360° rotation capability

용도 - Application

- 반도체/디스플레이 제조장비
Semiconductor/display equipment
- 공작기계/ATM장비, 캐비닛
Machine tool/ATM equipment, cabinet
- 프로파일 프레임장비 등
Profile Frame Equipment/etc.

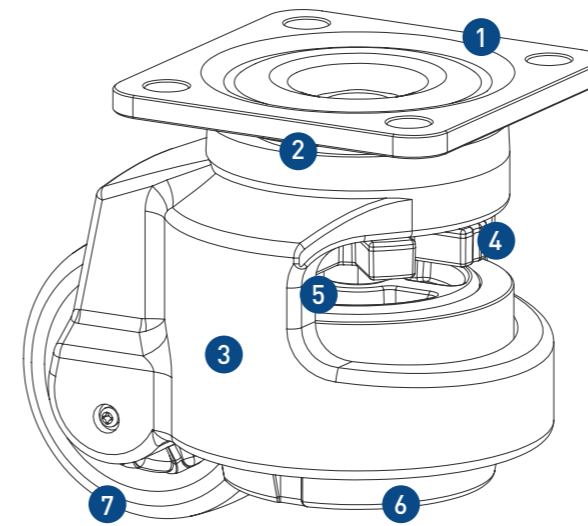

재질 & 표면처리 - Material & Treatment

NO.	재질	표면처리
① 상판(Top Plate)	SPC & S45C	Powder Coated
② 강구(Ball)	STB2	-
③ 몸체(Body)	ALDC12	Ivory/Powder Coated
④ 핸들(Handle)	40-100 PA6	Red
	120-150 S45C	Zinc Plating (MFZN)
⑤ 레벨러(Leveler)	Swrch10A/S45C	Zinc Plating (MFZN)
	40-100 NBR	Black
	120 PA6	
⑥ 패드(Pad)	150 ALDC12	
	40-120 PA6	Black
⑦ 바퀴(Wheel)	150 MC Nylon	Blue or Ivory

* Wheel Option: Poly urethane & MC Nylon by order

규격 - Dimension

Unit: mm

Model	자중 (Net Weight)	Kg		Ø	W	F	F1	Hole	Tap	X	Y	H+	L	O
		1EA	4EA											
KD-C01-1-40F	0.36	50	100	Ø40	20	55x55	42x42	Ø6.5	-	-	-	71+10	77.5	30
KD-C01-1-40S	0.37	-	-	-	-	-	-	-	M8 (M12)	46	40	-	-	-
KD-C01-1-60F	0.67	250	500	Ø50	25	73x73	58x58	Ø7 (Ø8.5)	-	-	-	82+10	97.5	36
KD-C01-1-60S	0.62	-	-	-	-	-	-	-	M12 (M16)	53	49	-	-	-
KD-C01-1-80F	1.19	500	1,000	Ø62	28	90x90	70x70	Ø9	-	-	-	103+15	122	46
KD-C01-1-80S	1.11	-	-	-	-	-	-	-	M12 (M16)	69	65	-	-	-
KD-C01-1-100F	1.65	750	1500	Ø75	30	95x95	70x70	Ø11	-	-	-	120+12	138	53
KD-C01-1-100S	1.55	-	-	-	-	-	-	-	M16	69	65	-	-	-
KD-C01-1-120F	1.65	1,000	2,000	Ø75	30	95x95	70x70	Ø11	-	-	-	120+12	138	53
KD-C01-1-120S	1.55	-	-	-	-	-	-	-	M16	69	65	-	-	-
KD-C01-1-150F-M	3.34	1,500	3,000	Ø90	55	100x100	70x70	Ø13	-	-	-	132+15	164	69