

# HF-1088W 이중 시건 장치 핸들 - Handle for double locking

A-2



**특징**

- 이중 시건으로 보안성이 우수합니다.
- 스테인레스 재질로 내식성, 내구성이 우수합니다.
- 방수 기능.
- 좌, 우 겸용입니다.
- 회전각 90°
- 각 키 페이지 참조.
- IP65 등급 보유.

**사양**

- 재질 : 스테인레스(STS304)
- 표면처리 : 광택 연마

**용도**

- 원자, 수, 화력발전소, 수전반, 배전반, 제어반, 선박, 이화학기기, 시험기기 등.

**Features**

- Superior security by double-lock unit structure.
- Made of stainless steel for durability and corrosion resistance.
- Waterproof.
- Use in both of right and left.
- Rotation angle 90°
- Refer to page for individual keys.
- It's rated IP65.

**Specification**

- Materials Used : Stainless(STS304)
- Finish : Satin polishing

**Use**

- Nuclear, Thermal, Water power plant, Vessel, Incoming panel, Physico-chemistry instruments, Distributing panel, Testing apparatus, etc.

※ 락핸들 페이지 참고(p.556~571)      ※ Refer to the lock handle page (p.556~571)  
 ※ 기본 락핸들 5, 6번 사용                ※ Use the Lock Handle No. 05, 06  
 ※ 락핸들 별도 판매                        ※ Separate purchase : Lock Handle

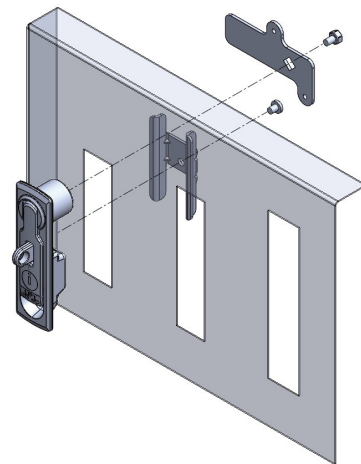
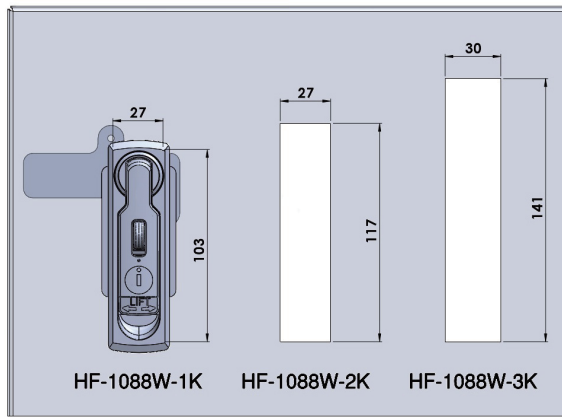

Installation Method

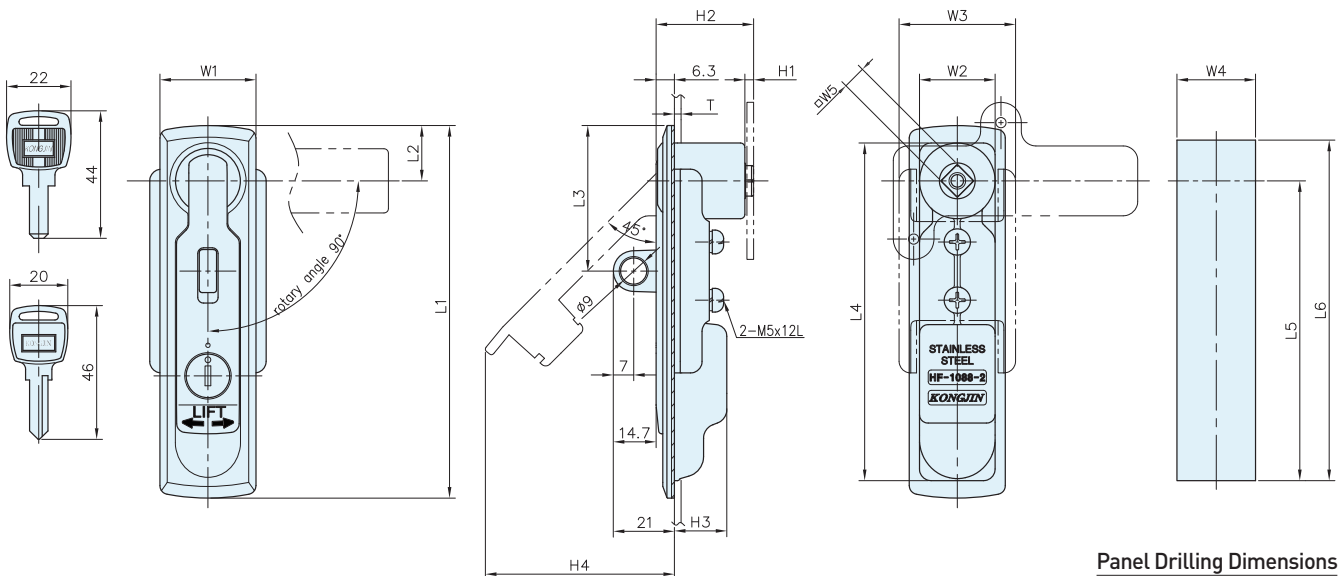

Panel Drilling Dimensions

R200 KEY	코드번호	DIMPLE KEY	코드번호	SIDE BAR KEY	코드번호	L1	L2	L3	L4	L5	L6	H1	H2	H3	H4	W1	W2	W3	W4	W5	Net weight(g)
HF-1088W-1K	KA02410	HF-1088WD-1K	KA02419	HF-1088WS-1K	KA02413	114	19	51	102	89	103	3	33.5	18	56	33	26	40	27	8	354
HF-1088W-2K	KA02411	HF-1088WD-2K	KA02421	HF-1088WS-2K	KA02415	128	19	50	116	103	117	3	33.5	18	65	33	26	40	27	8	379
HF-1088W-3K	KA02412	HF-1088WD-3K	KA02423	HF-1088WS-3K	KA02417	153	21.5	73	140	125	141	5.8	40	20	79	38	29	47	30	10	602