



H-9 HC-1111 스테인레스 캠 록- Stainless Cam Lock



특징

- 스테인레스 재질로 내식성, 내구성이 우수합니다.
- 방수 기능.

사양

- 재질 : 캠 록 - 스테인레스(STS)
키 - 아연 (ZDC II)
- 표면처리 : 광택연마

용도

- 반도체 장비, 정보통신 장비, 분전반, 배전반 등.

Features

- Made of stainless steel for durability and corrosion resistance.
- Waterproof.

Specification

- Materials Used : Cam lock - Stainless(STS)
KEY - ZDC II
- Finish : Satin polishing

Use

- Semiconductor equipment, IT equipment, Distributing panel, etc.

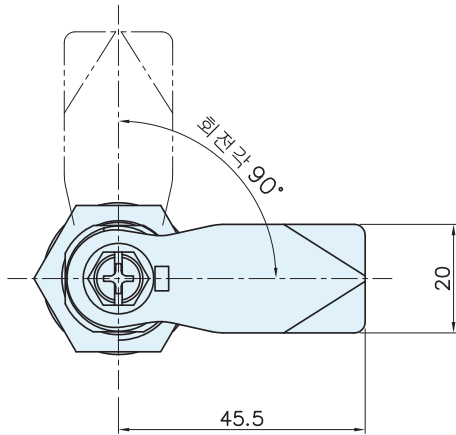

※ KEY 포함 제품 : HC-1111K
HC-1111T
미포함 제품 : HC-1111C
HC-1111H

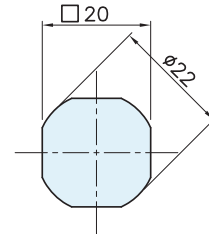
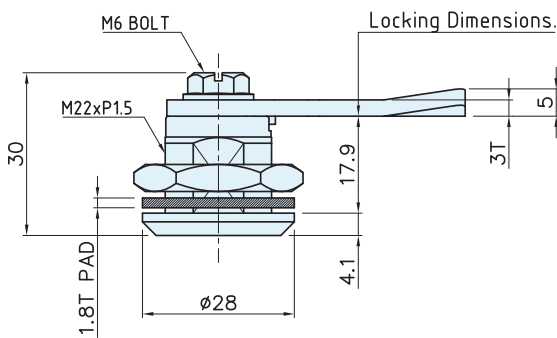

PANEL DRILLING DIMENSIONS.

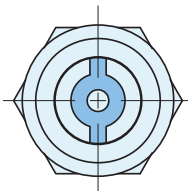

HC-1111K

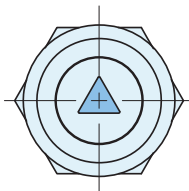

HC-1111T

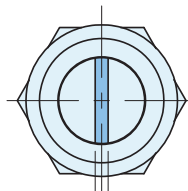

HC-1111C

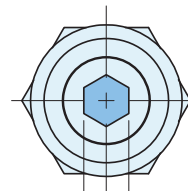

HC-1111H

	코드번호	Net weight[g]
HC-1111K	HC00104	90
HC-1111T	HC00105	90
HC-1111C	HC00106	90
HC-1111H	HC00107	90