



C-3 KC-101N,102N 캠 록 - Cam Lock



특징

- 노브를 돌려 사용합니다.
- 진동에 강합니다.
- 방수 기능.
- 좌, 우 별도입니다.

사양

- 재질 : 아연 합금(ZDCII)
- 표면처리 : 블랙 크롬 도금
- 제품중량 : KC-101N : 108g
KC-102N : 44g

용도

- 정보통신 장비, 반도체 장비, 분전반, 배전반, 제어반, 산업용 기계, 이화학기기, 시험기기 등.

Features

- Turn the knob to use it.
- Resistant to vibration.
- Waterproof.
- Use separately right and left.

Specification

- Materials Used : Zinc alloy(ZDCII)
- Finish : Black chrome plating
- Weight : KC-101N : 108g
KC-102N : 44g

Use

- IT equipment, Semiconductor equipment, Distributing panel, Control panel, Industrial machinery, Physico-chemistry instruments, Testing apparatus, etc.

※ 락핸들 페이지 참고(p.532~549)

※ 기본 락핸들 54,43번 사용

※ 락핸들 별도판매

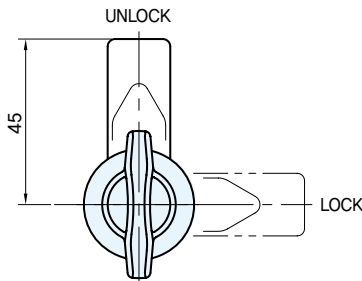
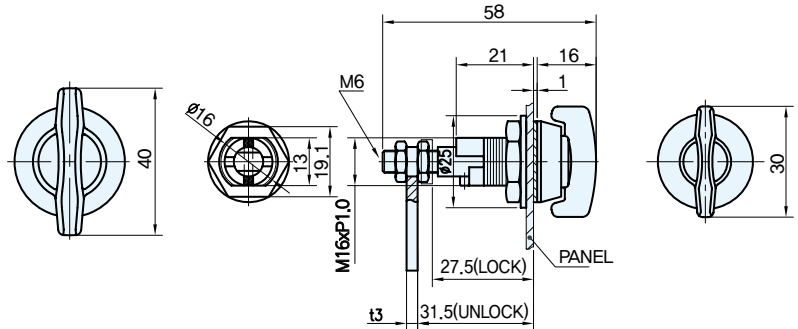
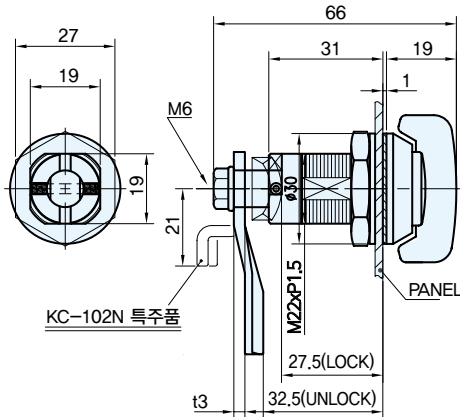
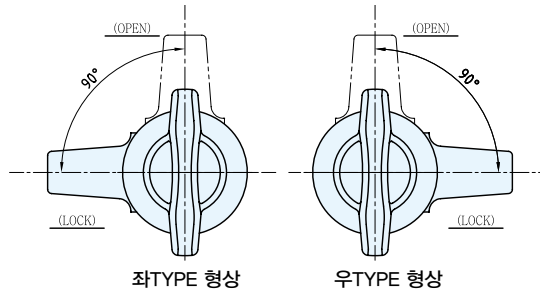

KC-101N

Panel Drilling Dimensions

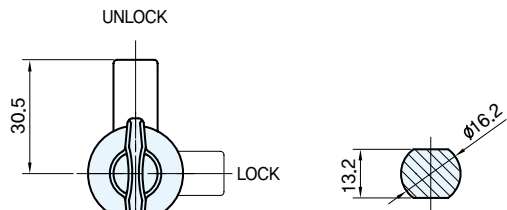

KC-102N

Panel Drilling Dimensions

* KC-102N 특주품 사용시 CLOSE : 36, OPEN : 40

코드번호	규격
KC-101N-B	KC00015 좌
KC-101N-B	KC00016 우
KC-102N-B	KC00036 좌
KC-102N-B	KC00037 우