

# KD-1102 스테이 - Stay

D-8



**특징**

- 스테인레스 재질로 내식성, 내구성이 우수합니다.
- 좌, 우 별도입니다.

**사양**

- 재질 : STS304
- 표면처리 : 바렐 연마

**용도**

- 정보통신 장비, 반도체 장비, 분전반, 배전반, 제어반, 산업용 기계, 이화학기기, 시험기기 등.

**Features**

- Made of stainless steel for durability and corrosion resistance.
- Use separately right and left.

**Specification**

- Materials Used : STS304
- Finish : Barrel polishing

**Use**

- IT equipment, Semiconductor equipment, Distributing panel, Control panel, Industrial machinery, Physico-chemistry instruments, Testing apparatus, etc.

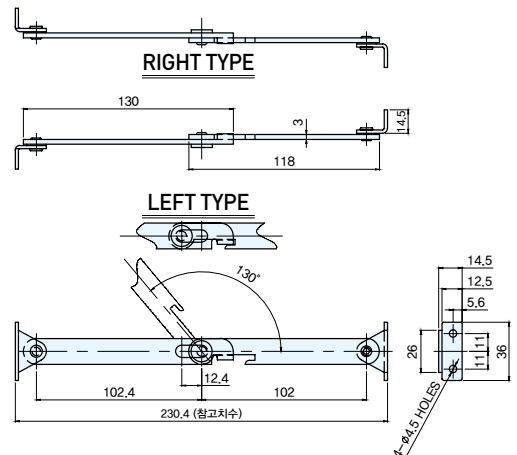
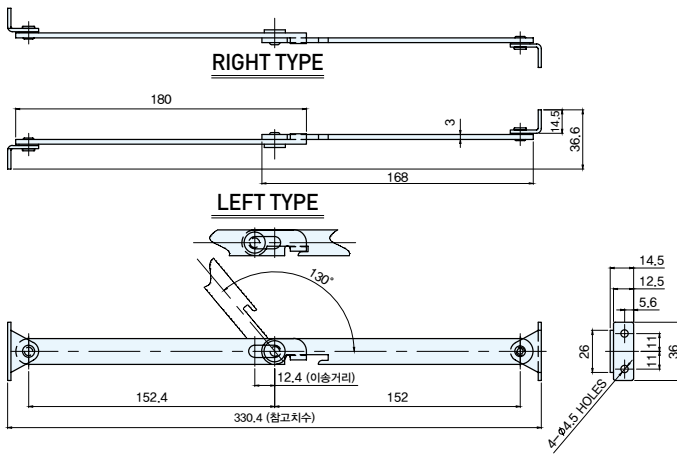
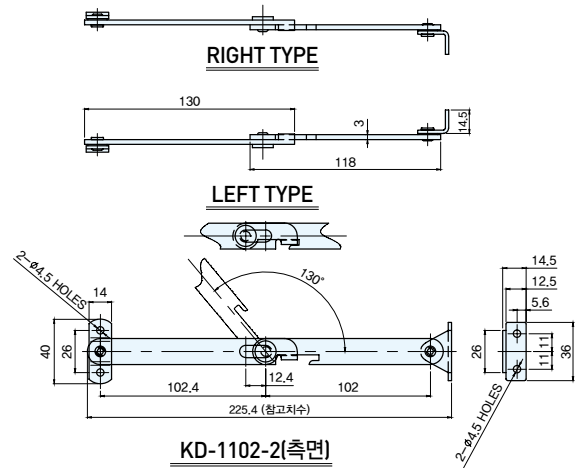
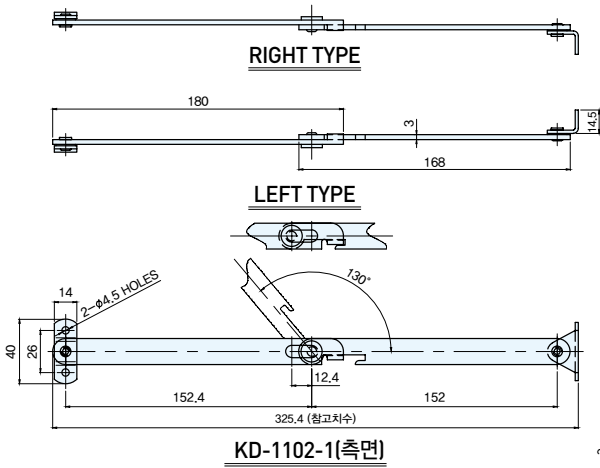

SCALE 1 : 1  
**KD-1102-1(정면)**

SCALE 1 : 1  
**KD-1102-2(정면)**

	코드번호	코드번호	코드번호
KD-1102-1 (정면, 좌)	KD02246	KD-1102-2 (정면, 좌)	KD02113
KD-1102-1 (정면, 우)	KD02245	KD-1102-2 (정면, 우)	KD02112
KD-1102-1 (측면, 좌)	KD02233	KD-1102-2 (측면, 좌)	KD02115
KD-1102-1 (측면, 우)	KD02232	KD-1102-2 (측면, 우)	KD02114