



D-3 도어 가스켓 - Door Gasket



특징
·형상이 다양하고 밀폐성이 우수합니다.

사양
·재질 : EPDM
·난연 타입 : 난연 EPDM (V-0)
·권장 사용 온도 : -30°C~70°C

용도
·정보통신 장비, 분전반, 배전반, 제어반 등.

Features
·Vary in shape and is highly airtight.

Specification
·Materials Used : EPDM
·Flame Retardant Type : Flame retardant EPDM (V-0)
·Recommended Operating Temperature : -30°C~70°C

Use
·IT equipment, Distributing panel, Control panel, etc.

※ 난연 타입 제작 별도 문의

※ Flame retardant type production separately inquiry

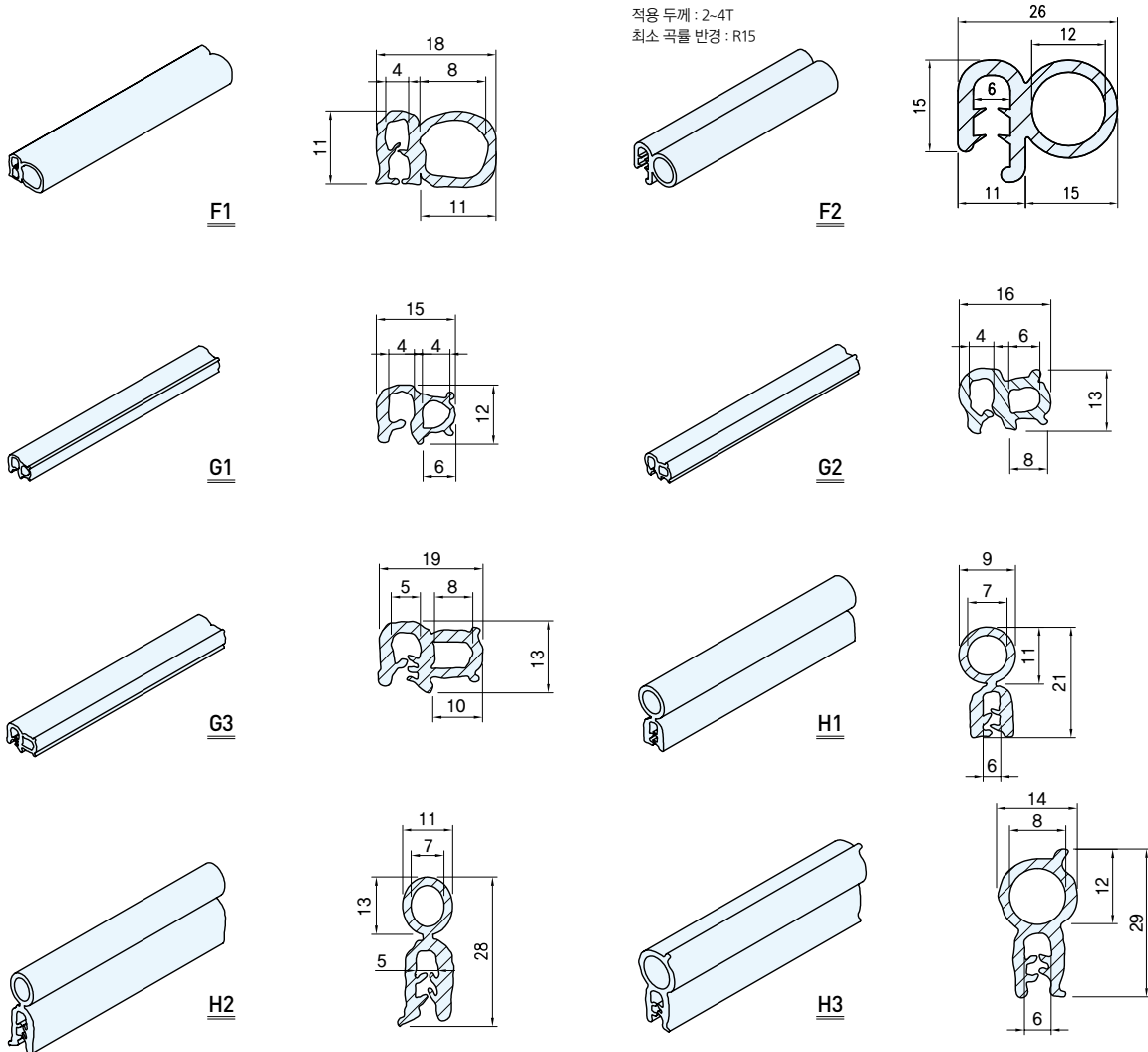

	코드번호		코드번호
DOOR GASKET F1	KD02011	DOOR GASKET G3	KD02015
DOOR GASKET F2	KD02012	DOOR GASKET H1	KD02016
DOOR GASKET G1	KD02013	DOOR GASKET H2	KD02017
DOOR GASKET G2	KD02014	DOOR GASKET H3	KD02018