

HC-P90N 조절식 노브 캠록 - Adjustable Knob Cam Lock

H-8



특징

- 키 없이 노브를 돌려서 사용
- 록킹 간격 조절 가능
- Lock-Open시 클릭감 있음
- 회전각 90°
- 보급형 제품

사양

- 재질 : ABS, ZDC, SPCC
- 색상 : 검정

용도

- 정보통신 장비, 반도체 장비, 분전반, 배전반 제어반, 산업용 기계, 이화학기기, 시험기기 등

Features

- Use by turning the knob without a key
- Adjustable locking distance
- Clicking when operating the knob
- Rotation angle - 90°
- Entry level products

Specification

- Materials Used : ABS, Zinc alloy, SPCC
- Color : Black

Use

- IT equipment, Semiconductor equipment Distributing panel, Control panel, Industrial machinery, Physico-chemistry instrument, Testing apparatus, etc.

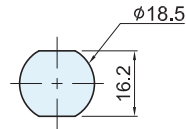
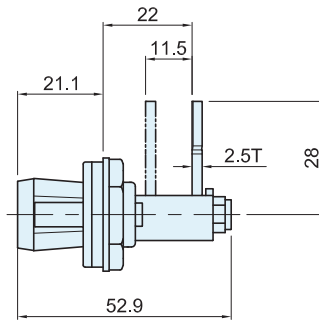
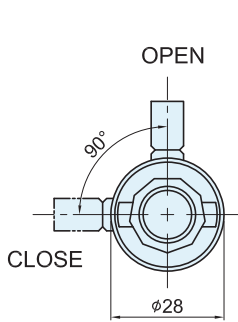

PANEL DRILLING DIMENSIONS.

MODEL : HC-P90N-1

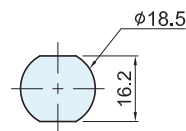
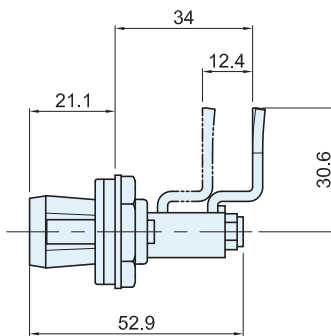
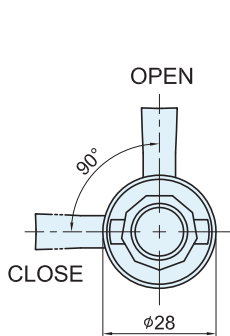

PANEL DRILLING DIMENSIONS.

MODEL : HC-P90N-2

	코드번호	Net weight[g]
HC-P90N-1	C090010	30
HC-P90N-2	C090030	32