

KL-F06-MR/MSR Series

중·고하중용, 방진용 - Medium & Heavy duty purpose, Chshioning type

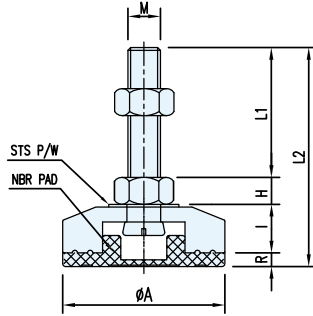

• 제품특징 Feature

단조후 가공품으로 중고하중용, 방진용 (Medium & heavy duty purpose with mechanical working after forging, Chshioning type)

• 적용범위 Application

컨베이어, 자동화설비, 반도체장비, 디스플레이설비, 이차전지설비 (Conveyor, Automation facilities, Semiconductor equipment, Display equipment, Secondary battery equipment)

규격 - Dimension & Material

Unit: mm

Model	Dimension (mm)							Road (Kg/4EA)	Material		Treatment	
	M	L1	L2	H	I	R	ØA		Bolt & Nut	Cup		
KL-F06-MR (Steel) KL-F06-MSR (STS)	M12x1.75	70	106	8		18		Ø53	1,000	S10C	S45C	Ni
		100	136									
		130	166									
		150	186									
		70	108									
		100	138									
		130	168									
		150	188									
	M16x2.0	50	90	10		19		Ø63	2,000			
		70	110									
		100	140									
		130	170									
		150	190									
		180	220									
		200	240									
		250	290									
		50	95									
		70	115									
		100	145									
		130	175									
	150	195										
	180	225										
	200	245										
	250	295										
M20x2.5	100	143	13		19	9	Ø63	3,000				
	130	173										
	150	193										
	180	223										
	200	243										
	250	293										
	100	148										
	130	178										
	150	198										
	180	228										
	200	248										
	250	298										
M24x3.0	150	201	16		25			4,000				
	200	251										
	150	209										
	200	259										
M30x3.5	150	213	20		30	12	Ø98	5,000				
	200	263										
	250	313										

* 기타 특수사양은 주문제작함 (Particular case is Made-To-Order)